

## CLOSING ROTATIONAL MODULE ZIGMAT 180-2 TYPE: Z-1422

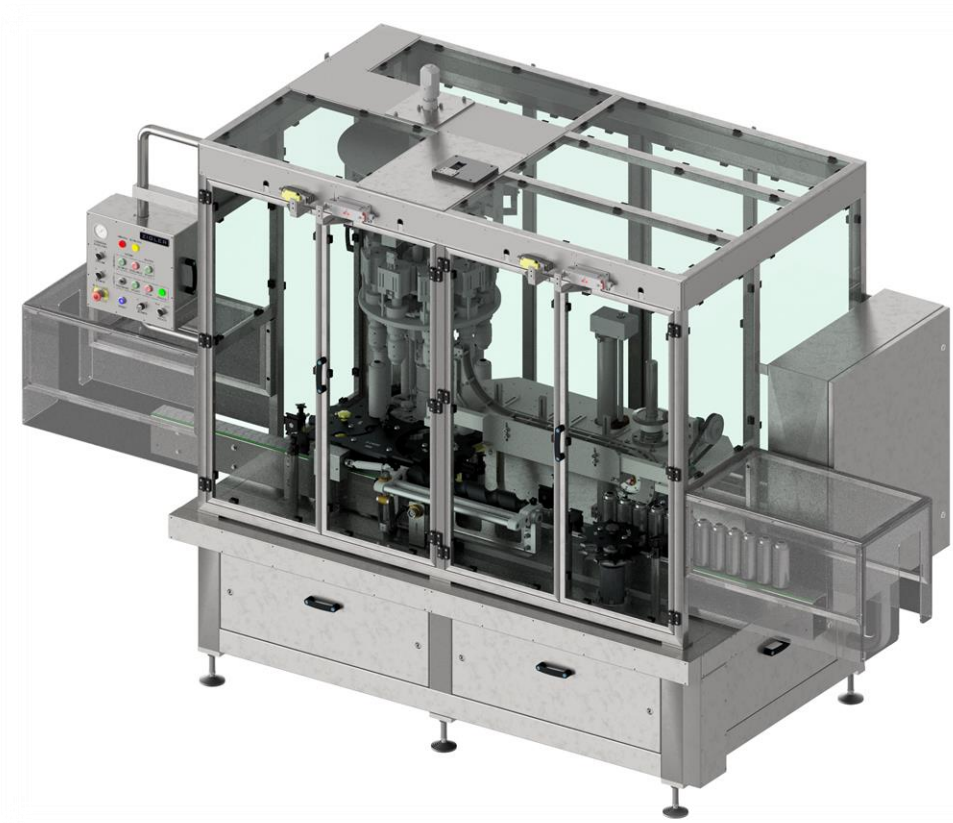

Closing Rotational Module ZIGMAT Z-1422 is part of an automatic aerosol production line and is designed to drop aerosol valves into containers and then clamp them onto the containers. The process is carried out by a valve insertion module and a rotary closing station equipped with 9 actuators.



# ZIGLER

AEROSOL & FILLING TECHNOLOGY

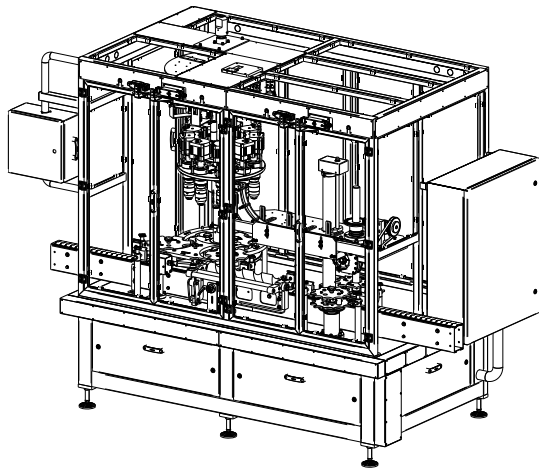

## Working parameters

Capacity: 180 pcs/minute  
Working pressure: 0.6 ÷ 0.8 MPa (6÷8 bar)

## Dimensions and weight

Width: 3125 mm  
Length: 1465 mm  
Height: 2435 mm  
Weight: ~2300 kg

## Supply parameters

Supply type: Electric and pneumatic  
Required supply voltage: 3x400 VAC, 50Hz  
Required supply pressure: 0,8 ÷ 1,0 MPa (8 ÷ 10 bar)  
Quality of compressed air: IV-th class (according to ISO 8573-1) for temperatures 15 ÷ 35°C  
Air supply connection: External thread G<sup>3/4</sup>"

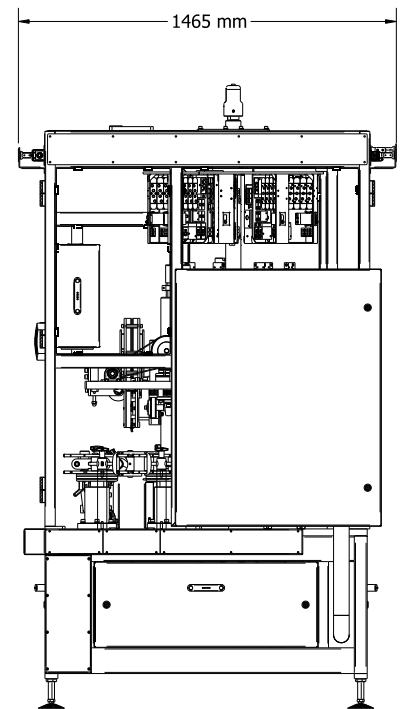
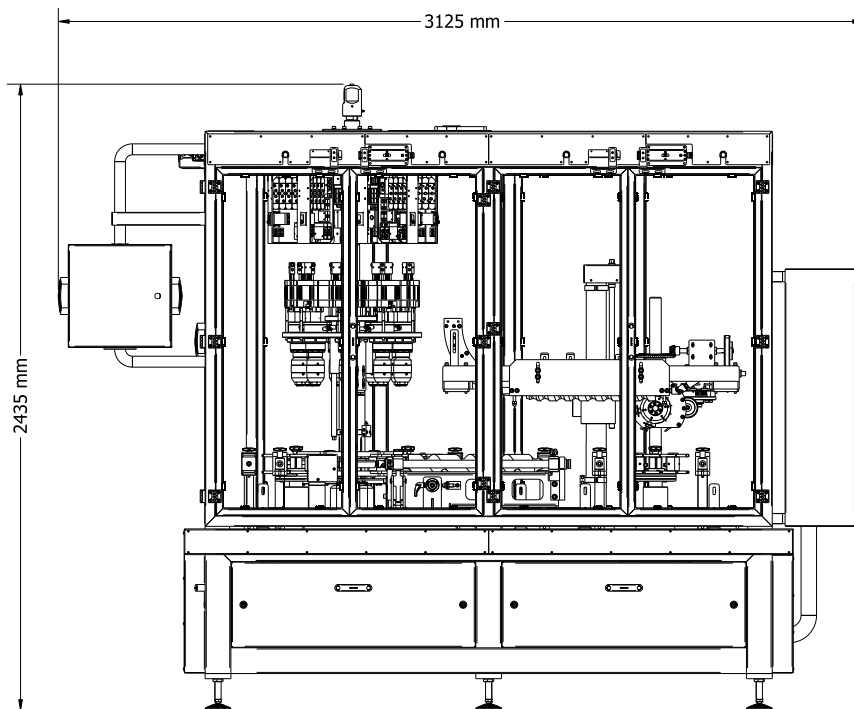

 **ZIGLER POLSKA Sp. z o.o.**  
ul. Braci Gutmanów 7  
43-600 Jaworzno  
POLAND  
 +48 32 616 36 70

 [biuro@zigler.pl](mailto:biuro@zigler.pl)  
[zigler@zigler.pl](mailto:zigler@zigler.pl)  
 [www.zigler.pl](http://www.zigler.pl)

VAT UE: PL6772294223  
REGON: 120491798  
KRS: KRS nr 0000032816  
Sąd Rejonowy Katowice-Wschód  
w Katowicach

**BANK ACC.**  
**ING BANK ŚLĄSKI**  
PLN 56 1050 1360 1000 0090 3033 8132  
EUR 94 1050 1360 1000 0024 0995 9893  
SWIFT: INGBPLPW