

## VIBRATORY SORTER TYPE: Z-3071

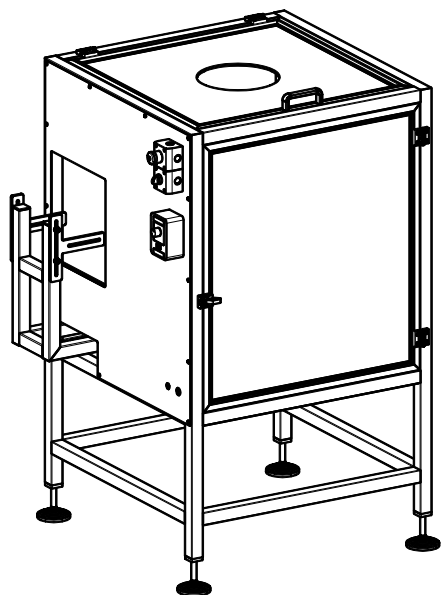

Vibratory Sorter Z-3071 is a machine for feeding appropriately oriented elements (sprayheads, caps, valves) to the inserting/closing machine. Vibratory Sorter Z-9071 construction provides acoustic insulation that protects line operators against noise from vibrations. The machine is equipped with dedicated control cassettes to control operation of Vibratory Sorter and with a mounting adapter to properly install output conveyor.





### Dimensions and weight

Width: 1010 mm  
Length: 875 mm  
Height: 1510 mm  
Weight: ~247 kg

### Supply parameters:

Supply type: Electric  
Supply voltage: 230 VAC, 50 Hz  
Power: 0.16 kW

