

VALVES SORTER TYPE: Z-3009

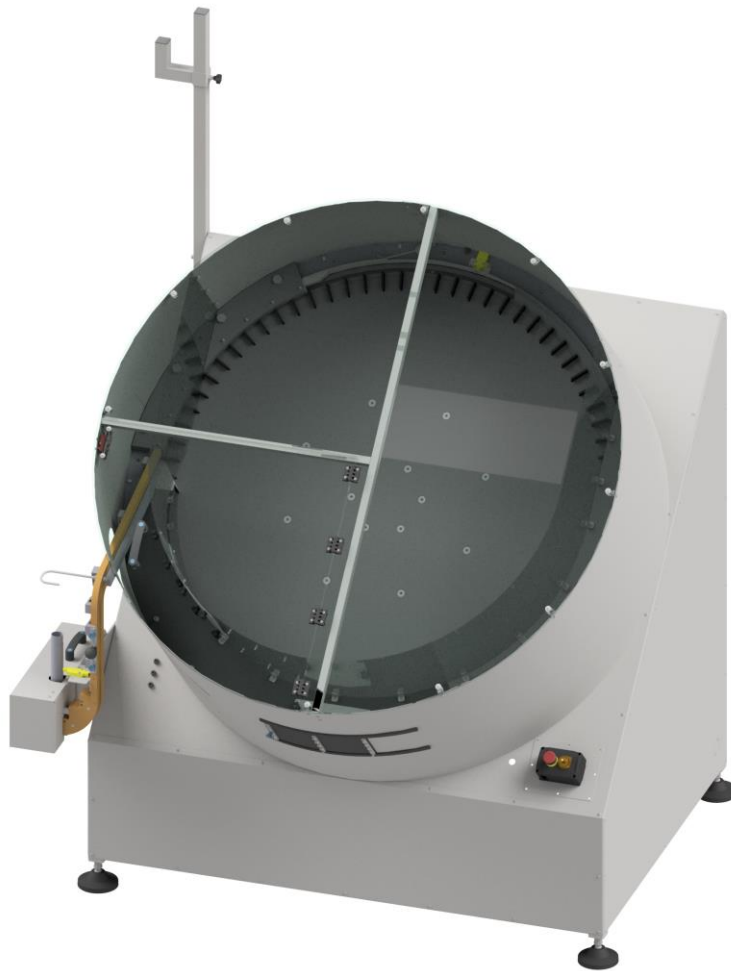

Valves sorter is a machine for feeding appropriately oriented (sorted) aerosol valves to the valve inserting module installed in filling/closing machine. Sorter is equipped with an electric drive of the sorting disc and the machine operation is controlled by a sensors system located at the sorting hopper and feeding guide. A special machine design allows for an optimal arrangement of sorted valves so that they enter the guide in right direction and may be immediately inserted onto the aerosol can.

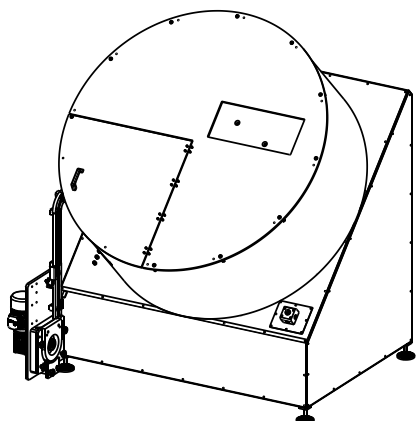



Working parameters:

Capacity: up to 10800 pcs/hour
(180 pcs/min)

Maximal valve length: 320 mm (with the tube)

Dimensions and weight:

Width: 1755 mm

Length: 1665 mm

Height: 2120 mm

Weight: ~670 kg

Supply parameters:

Supply type: Electric and pneumatic

Supply voltage: 3x230 VAC, 50 Hz

Supply pressure: 8 - 10 bar (0.8 - 1.0 MPa)

Drive system:

Motor power: 0,75 kW

Rotation: 1370 rpm

Reducer ratio i=80

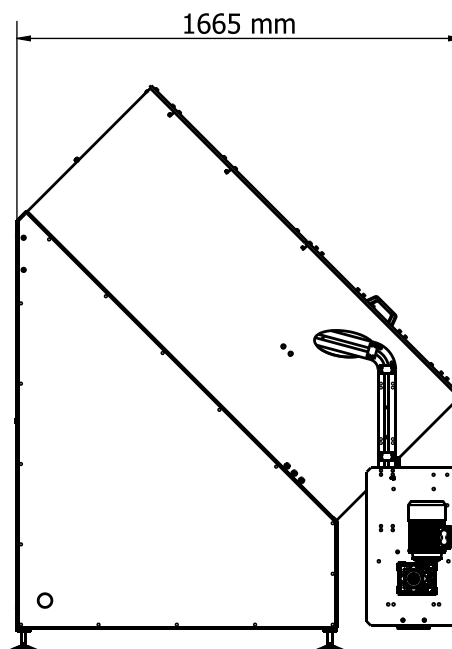
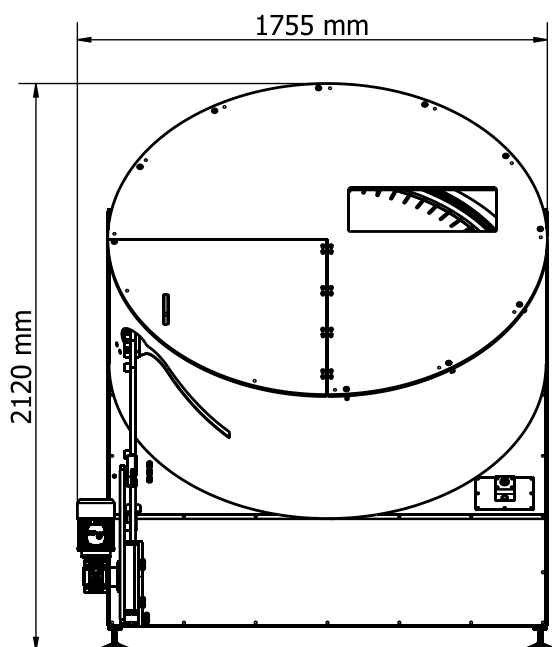

ZIGLER POLSKA Sp. z o.o.

ul. Braci Gutmanów 7

43-600 Jaworzno

POLAND

+48 32 616 36 70

biuro@zigler.pl

zigler@zigler.pl

www.zigler.pl

VAT UE: PL6772294223

REGON: 120491798

KRS: KRS nr 0000032816

Sąd Rejonowy Katowice-Wschód
w Katowicach

BANK ACC.

ING BANK ŚLĄSKI

PLN 56 1050 1360 1000 0090 3033 8132

EUR 94 1050 1360 1000 0024 0995 9893

SWIFT: INGBPLPW

Our offer also includes a variant of the sorter Z-3009 prepared for high-capacity lines of the Zigmat type with a production of up to 200 pcs/min.

