

## SPRAYHEAD INSERTER TYPE: Z-1123

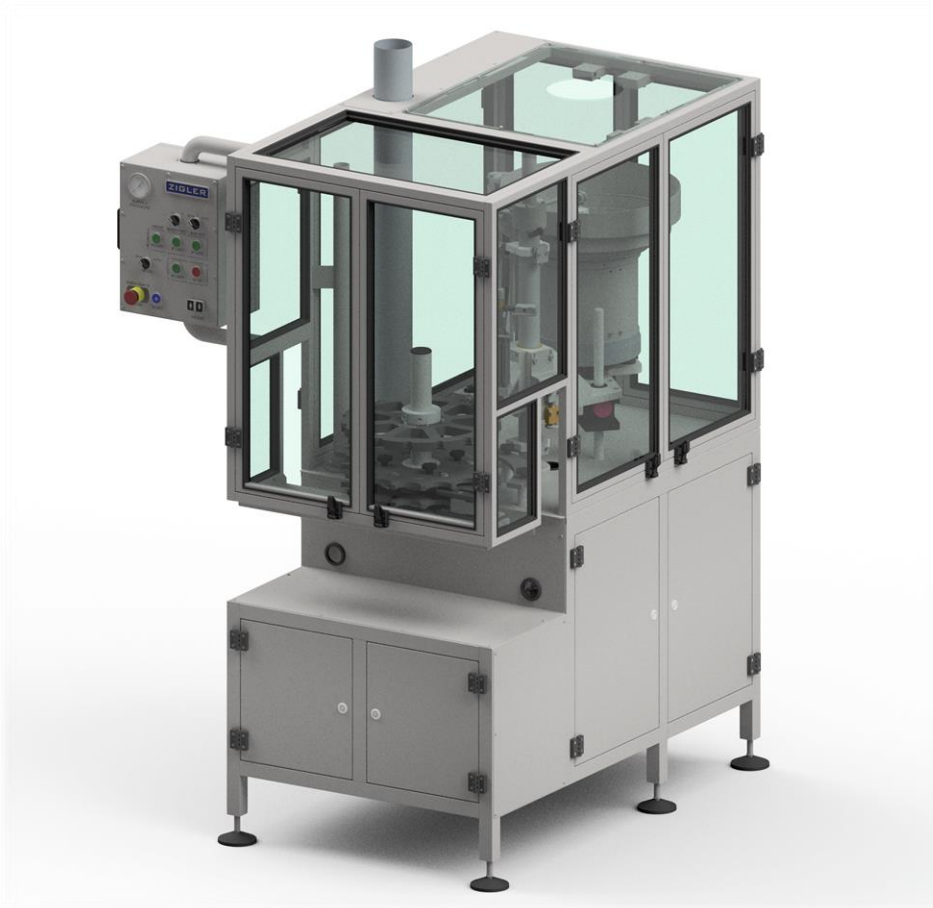

Sprayhead Inserter Z-112 is a part of automatic aerosol production line and is designed to place firmly the sprayhead (spraybutton, actuator) on aerosol can with crimped valve. Sprayhead Inserter Z-1123 is designed for use with conveyor belt Z-5300 type, thanks to specially designed geometry of indexing wheel which collects the containers straight out from the belt. The machine is also equipped with vibratory feeder installed inside its working space. The selection of active module can be made using control panel.



# ZIGLER

AEROSOL & FILLING TECHNOLOGY

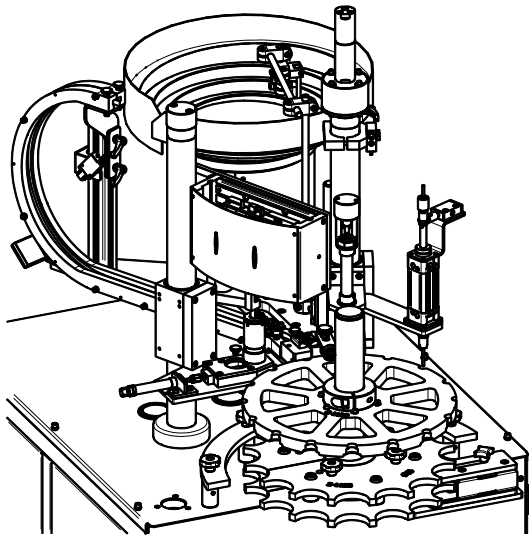

## Operational parameters

Production capacity: 3000 - 3600 pcs/hour (50 - 60 pcs/minute)

Containers diameter:  $\varnothing 35$  mm -  $\varnothing 66$  mm (with the use of exchangeable equipment)

Containers height: 125 mm - 370 mm

## Overall dimensions and weight

Width: 1250 mm

Length: 1365 mm

Height: 1975 mm

Weight: ~565 kg

## Supply

Type of supply: Compressed air

Air supply pressure: 0.8 ÷ 1.0 MPa (8 ÷ 10 bar)

Air consumption: ~40 m<sup>3</sup>/h

Air supply connection: External thread G $\frac{1}{2}$ "

Compressed air 4<sup>th</sup> class according to ISO 8573-1 for quality: temperature range 15 ÷ 35°C

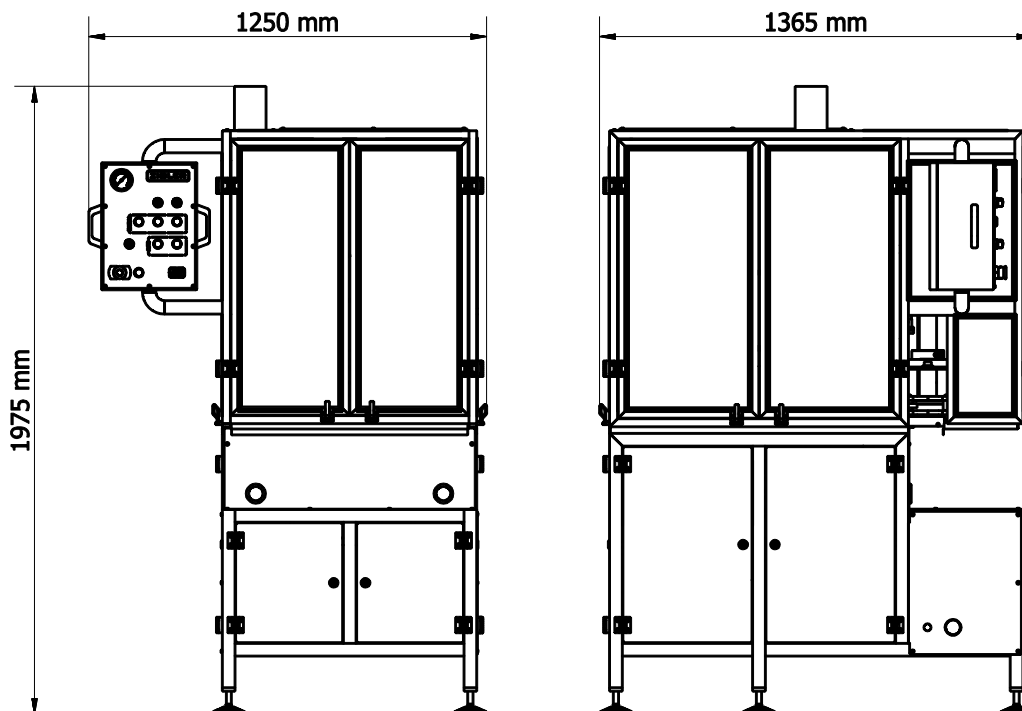

 ZIGLER POLSKA Sp. z o.o.

ul. Braci Gutmanów 7

43-600 Jaworzno

POLAND

 +48 32 616 36 70

 [biuro@zigler.pl](mailto:biuro@zigler.pl)

[zigler@zigler.pl](mailto:zigler@zigler.pl)

 [www.zigler.pl](http://www.zigler.pl)

VAT UE: PL6772294223

REGON: 120491798

KRS: KRS nr 0000032816

Sąd Rejonowy Katowice-Wschód  
w Katowicach

BANK ACC.

ING BANK ŚLĄSKI

PLN 56 1050 1360 1000 0090 3033 8132

EUR 94 1050 1360 1000 0024 0995 9893

SWIFT: INGBPLPW