

SIDE GRIP CONVEYOR TYPE: Z-5500

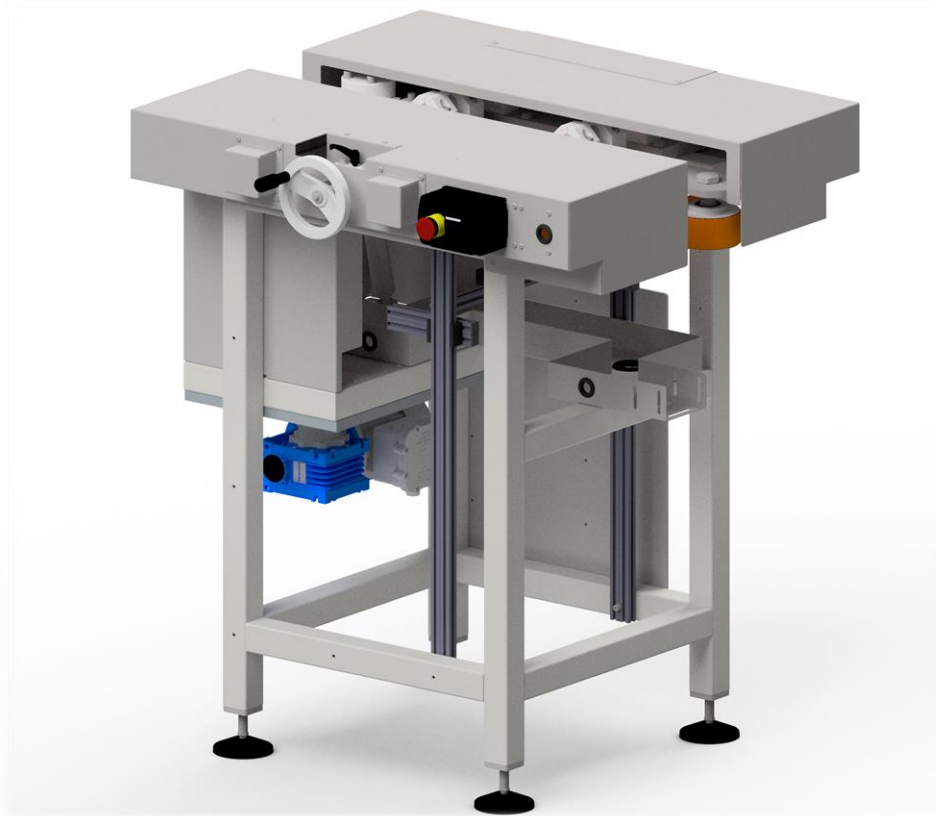

Main purpose of Side Grip Conveyor Z-5500 is to transport the containers between the individual production line machines. The device is equipped with 2 elastic belts whose task is to hold and transport containers.



ZIGLER

AEROSOL & FILLING TECHNOLOGY

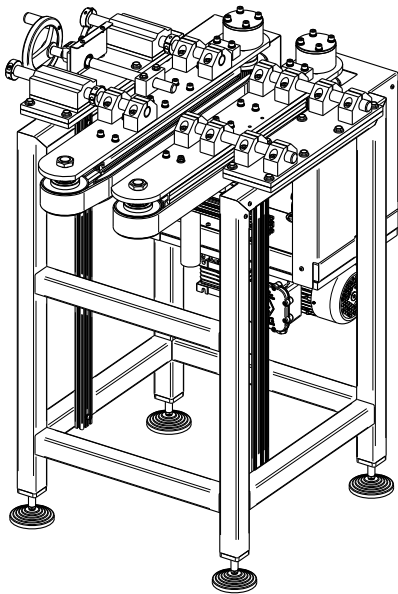

Dimensions and weight:

Width: 885 mm
Length: 930 mm
Height: 1110 mm
Weight ~195 kg

Drive system:

Motor power: 0.37 kW
Rotation: 1370 rpm
Reducer ratio: i=60

Supply:

Supply type: Electric
Supply voltage: 3x230V AC, 50Hz
Power: 0.37 kW

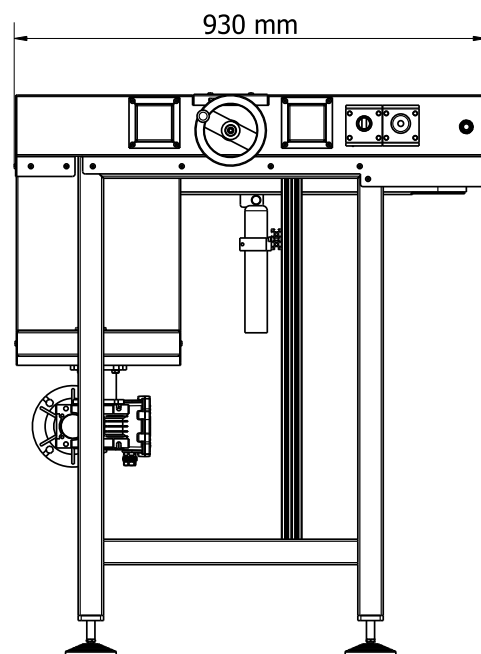
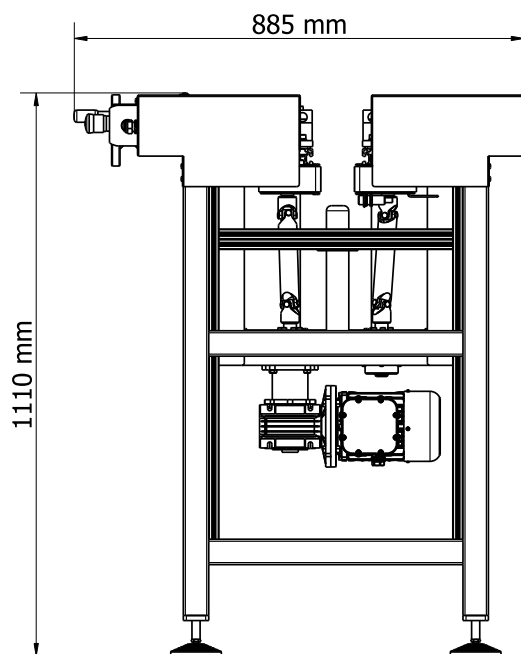

ZIGLER POLSKA Sp. z o.o.

ul. Braci Gutmanów 7
43-600 Jaworzno
POLAND

+48 32 616 36 70

biuro@zigler.pl

zigler@zigler.pl

www.zigler.pl

VAT UE: PL6772294223

REGON: 120491798

KRS: KRS nr 0000032816

Sąd Rejonowy Katowice-Wschód
w Katowicach

BANK ACC.

ING BANK ŚLĄSKI

PLN 56 1050 1360 1000 0090 3033 8132

EUR 94 1050 1360 1000 0024 0995 9893

SWIFT: INGBPLPW