

SEMI-AUTOMATIC RINGS (COLLARS) INSERTER TYPE: Z-2005

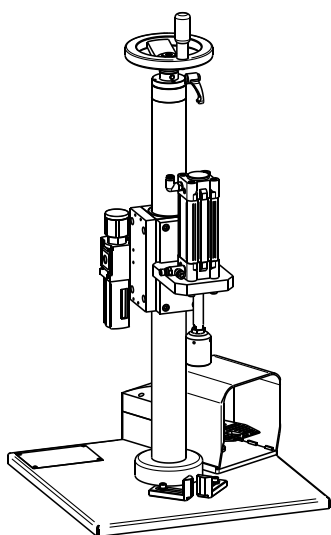

Semi-automatic ring embedding machine Z-2005 is a device used for permanent placement of decorative rings (collars) on containers with crimped atomizer. Rings function is to cover, in esthetical manner, the place of the crimp.





Working parameters

Production capacity: ~600 - 1800 pcs/h (10 - 30 pcs/min). The maximum capacity is dependent on collars geometry, work organization in the process line and operator's experience.

Supported rings diameters [mm]: Depending on diameter of provided inserting heads. In principle one head supports one ring diameter.

Bottles height: ~50 ÷ 300 mm

Dimensions and weight

Width: 400 mm

Length: 400 mm

Height: 815 mm

Weight: ~43 kg

Power supply

Required supply pressure: 0.8 ÷ 1.0 MPa (8 ÷ 10 bar)

Air consumption: 0.75 litre/cycle

Compressed air quality: CLASS IV according to ISO 8573-1 for 15 ÷ 35°C:

