

## SEMI-AUTOMATIC BOV FILLING MACHINE TYPE: Z-2323

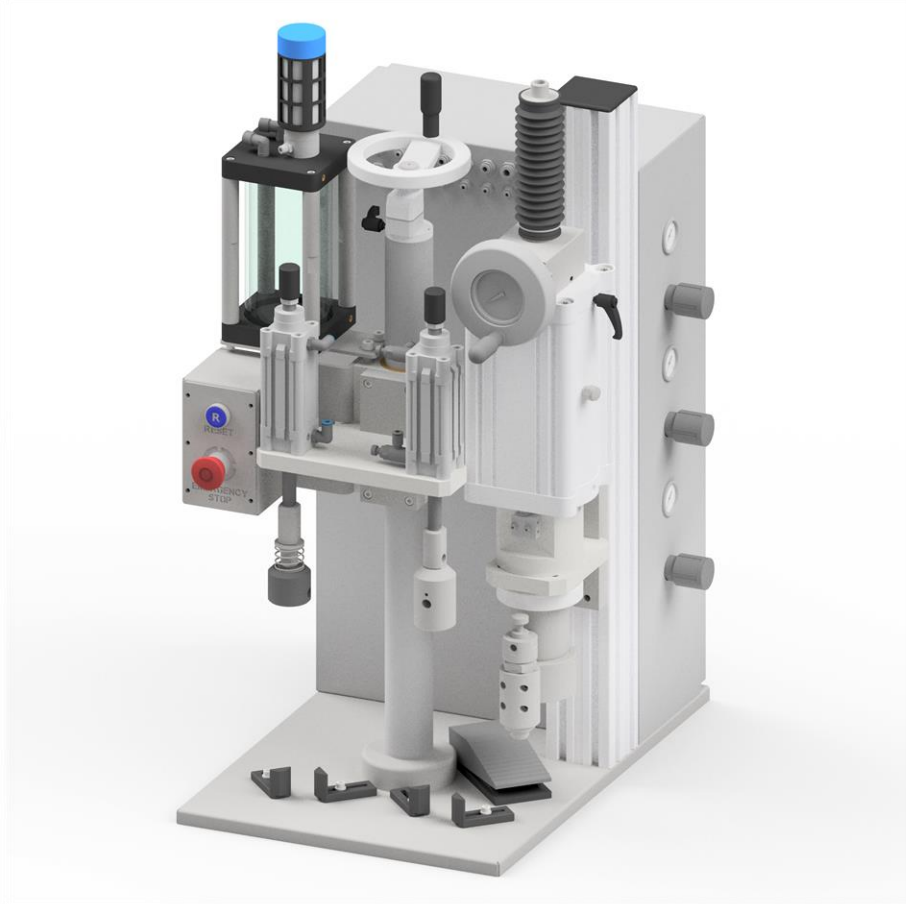

Z-2323 Semi-automatic BOV Filling Machine is a device designed for filling aerosol containers with liquid product through Bag-On-Valves crimped on the aerosol container. The amount of the dosed product is regulated in the range of 5 - 510 ml (for product cylinder  $\varnothing 50$  mm) with tolerance up to  $\pm 0.5$  ml. Machine is equipped with 2 working heads:

- filling head – fills the container with liquid product. Additional sealing sleeve is installed to increase the purity and quality of filling process.
- cleaning head – cleans the valve's cup and stem after filling using vacuum system connected with a drain tank.



## Operational parameters

Production capacity:	1800 pcs/h (30 pcs/min) for 100 ml dose; 900 pcs/h (15 pcs/min) for 200 ml dose; 420 pcs/h (7 pcs/min) for 500 ml dose; The maximum capacity of the device is dependent on process organization and operator's experience
<sup>1</sup> Dosing tolerance:	± 0.5 ml for 100 ml dose; ± 0.7 ml for 200 ml dose; ± 1.0 ml for 500 ml dose;
Containers diameter:	ø35 mm ÷ ø66 mm
Containers height:	65 mm ÷ 320 mm

## Overall dimensions and weight

Width:	560 mm
Length:	590 mm
Height:	870 mm
Weight:	115 kg

## Supply

Type of supply:	Compressed air
Air supply pressure:	0.8 ÷ 1.0 MPa (8 ÷ 10 bar)
Air consumption:	21 litres / cycle
Air supply connection:	Pneumatic push-in fitting ø12 mm
Quality of compressed air:	4 <sup>th</sup> class according to ISO 8573-1 for temperature range 15 ÷ 35°C
Product supply pressure:	Up to 6 bar, depending on density, viscosity and consistence
Product connection:	G½" external BSPP thread with 60° cone

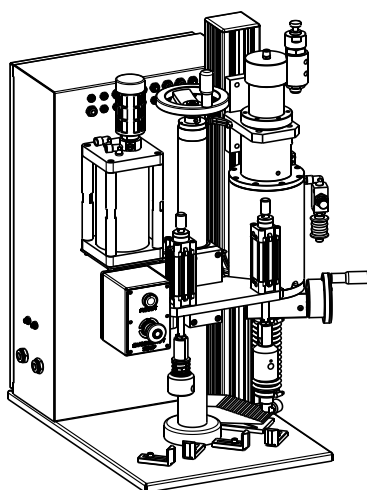

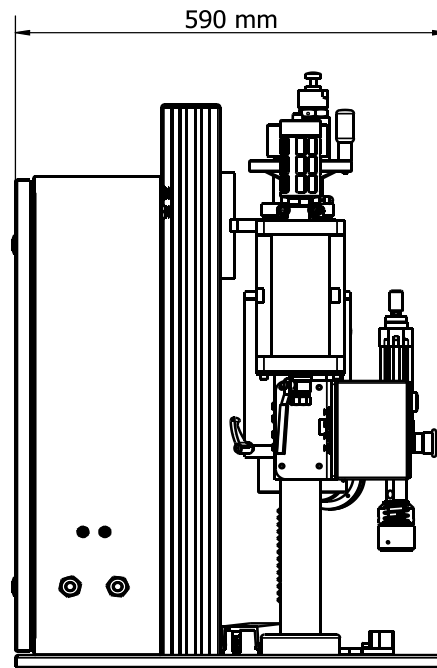
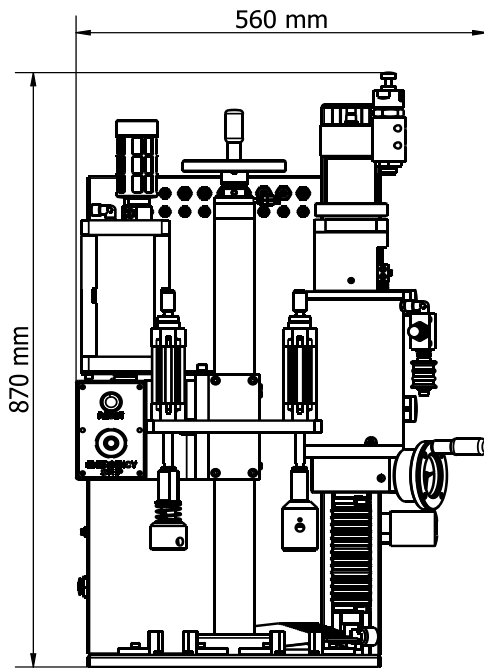

**ZIGLER POLSKA Sp. z o.o.**  
ul. Braci Gutmanów 7  
43-600 Jaworzno  
POLAND  
+48 32 616 36 70

**biuro@zigler.pl**  
**zigler@zigler.pl**  
**www.zigler.pl**

**VAT UE:** PL6772294223  
**REGON:** 120491798  
**KRS:** KRS nr 0000032816  
Sąd Rejonowy Katowice-Wschód  
w Katowicach

**BANK ACC.**  
**ING BANK ŚLĄSKI**  
PLN 56 1050 1360 1000 0090 3033 8132  
EUR 94 1050 1360 1000 0024 0995 9893  
SWIFT: INGBPLPW