

ROTATIONAL-INDEXING MODULE MRI 110/16 TYPE: Z-1300



MRI 110/16 is a device used to fill containers (glass or plastic bottles) with liquid product. Materials of the highest quality (stainless or acid resistant steel) are used for the MRI construction, thus creating working conditions even in a highly hazardous environment. MRI machine is designed to prevent a hazard of explosion during production process. Exchangeable indexing wheel sockets, easy and smooth regulation of modules height: filling and crimping, allow changing of production profile efficiently and, owing to this, the adaptation to quickly changing market demands does not create any problem.

As part of the standard equipment, bundled with the machine, the User receives 1 set of format inserts, which (depending on the geometry of the bottles) allow working with 1 or 2 types of bottles.



ZIGLER

AEROSOL & FILLING TECHNOLOGY

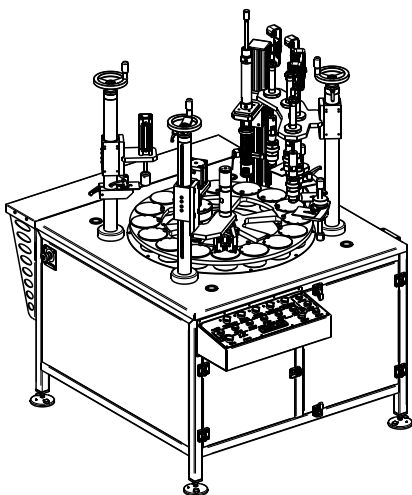

Operational parameters

Production capacity: Standard assumption is 1200 ÷ 1500 pcs/h (20 ÷ 25 pcs/min.) Resultant capacity depends on liquid product properties (tendency to lather), production organization and operators experience

Working pressure: 0.6 ÷ 0.8 MPa (6 ÷ 8 bar)

Dimensions and weight

Width: 1220 mm

Length: 1510 mm

Height: 1700 (+/- 50 mm of regulation)

Mass: 300 - 550 kg (depending on configuration)

Supply

Supply type: Pneumatic and electric (optional)

Air supply pressure: 0.8 ÷ 1.0 MPa (8 ÷ 10 bar)

Air consumption: 12 - 25 m³/h – depending on product dose and set capacity

Compressed air quality: CLASS IV according to ISO 8573-1 for 15 ÷ 35°C

Supply voltage (optional): 230V, 50 Hz.

Power (optional): 0.53 kW (optional)

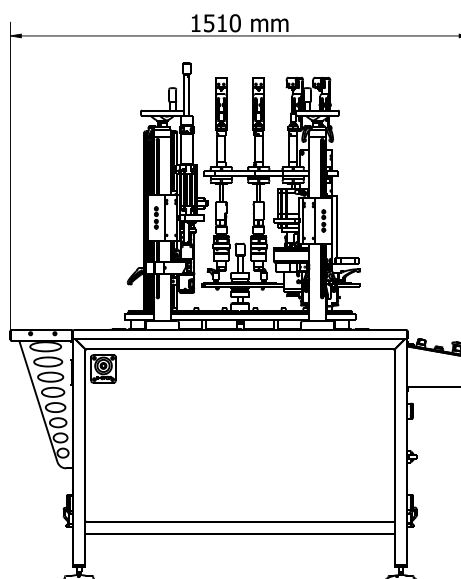
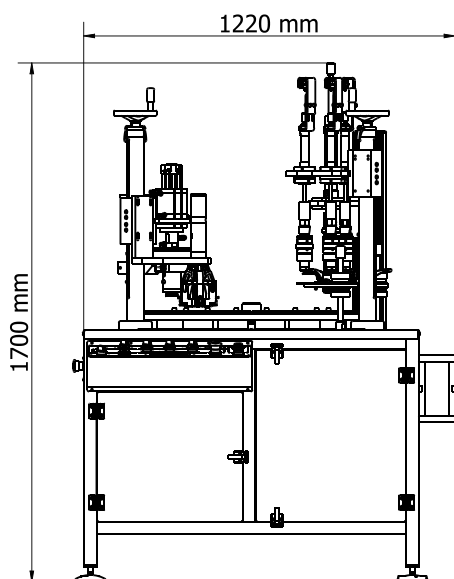

 ZIGLER POLSKA Sp. z o.o.

ul. Braci Gutmanów 7

43-600 Jaworzno

POLAND

 +48 32 616 36 70

 biuro@zigler.pl

zigler@zigler.pl

 www.zigler.pl

VAT UE: PL6772294223

REGON: 120491798

KRS: KRS nr 0000032816

Sąd Rejonowy Katowice-Wschód
w Katowicach

BANK ACC.

ING BANK ŚLĄSKI

PLN 56 1050 1360 1000 0090 3033 8132

EUR 94 1050 1360 1000 0024 0995 9893

SWIFT: INGBPLPW