

PRODUCT PUMP TYPE: Z-2109

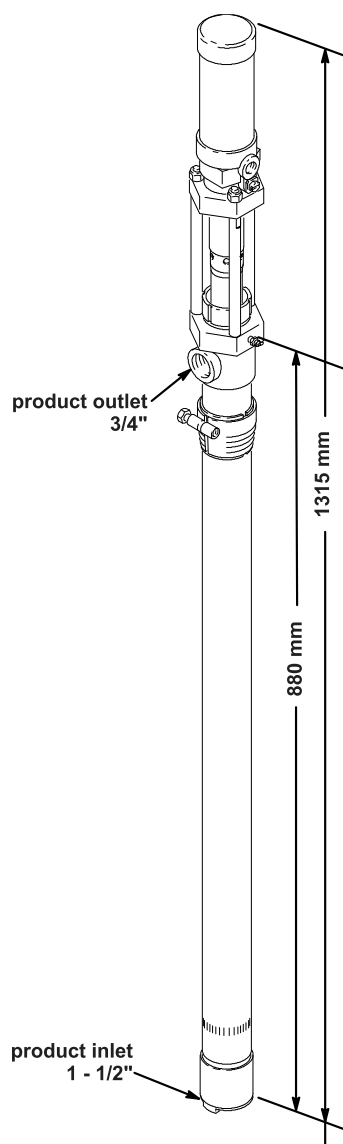

Liquid Product Pump is designed to operate at air input pressures up to 12 bar and delivers a smooth, reliable flow. Drum length and stubby models are available for either drum transfer or wall mount siphon feed applications. Ideal for dense fluids with plate (flat) check options. The working part is made of high quality, acid-resistant steel. The sealing used on the piston allows feeding of all kinds of liquid products required in aerosol production.





Operational parameters

Capacity: Up to 19 liters/min
 Product outlet connection: G $\frac{3}{4}$ "
 Compression ratio: 1/1
 (air pressure / liquid pressure)

Dimensions and weight

Total length: 1315 mm
 Effective piston diameter: 35.2 mm
 Stroke length: 101.6 mm
 Weight: ~10 kg

Supply

Supply type: Pneumatic
 Maximum inbound air pressure: 12 bar (1.2 MPa)
 Compressed air quality: CLASS IV according to ISO 8573-1 standard at temperature 15 ÷ 35°C
 Air supply connection: G $\frac{1}{4}$ "

