

FILLING AND CLOSING AUTOMATIC INDEXING MODULE TYPE: Z-1200



Filling and Closing Automatic Indexing Module Z-1200 is a machine which is a part of aerosol production line and is designed for perform following operations:

- Collecting empty containers from conveyor;
- Filling empty containers with liquid product using 1-4 filling modules;
- Placing aerosol valve on filled container;
- Crimping valves on aerosol container (with optional vacuum);
- Putting finished products back to conveyor.



ZIGLER

AEROSOL & FILLING TECHNOLOGY

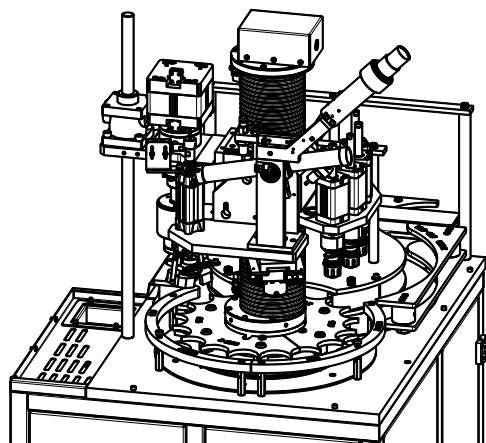

Operational parameters

Production capacity: 3000 – 3600 pcs/hour (50 - 60 pcs/minute).
The maximum capacity depends on product dose and machine configuration

Containers diameter: $\varnothing 35 \text{ mm} \div \varnothing 66 \text{ mm}$
Containers height: $65 \text{ mm} \div 320 \text{ mm}$

Overall dimensions and weight

Width: 1650 mm
Length: 1085 mm
Height: 2000 mm
Weight: ~650 – 800 kg (depending on configuration)

Supply

Type of supply: Compressed air
Air supply pressure: $0.8 \div 1.0 \text{ MPa}$ ($8 \div 10 \text{ bar}$)
Air consumption: Up to $65 \text{ m}^3/\text{h}$ (depending on configuration)
Air supply connection: External thread $G\frac{3}{4}''$
Quality of compressed air: 4th class according to ISO 8573-1 for temperature range $15 \div 35^\circ\text{C}$
Product supply pressure: Depending on density and consistence of product ($1 - 6 \text{ bar}$)
Product connection: $G\frac{1}{2}''$ external BSPP thread with 60° cone for each filling module

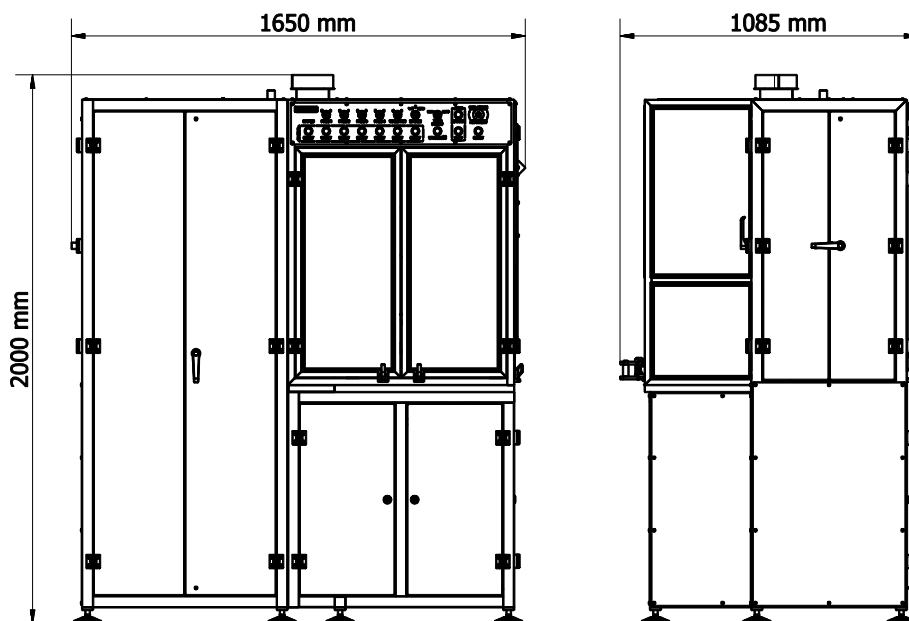

 **ZIGLER POLSKA Sp. z o.o.**
ul. Braci Gutmanów 7
43-600 Jaworzno
POLAND
 +48 32 616 36 70

 biuro@zigler.pl
zigler@zigler.pl
 www.zigler.pl

VAT UE: PL6772294223
REGON: 120491798
KRS: KRS nr 0000032816
Sąd Rejonowy Katowice-Wschód
w Katowicach

BANK ACC.
ING BANK ŚLĄSKI
PLN 56 1050 1360 1000 0090 3033 8132
EUR 94 1050 1360 1000 0024 0995 9893
SWIFT: INGBPLPW