

## FILLING AND CLOSING AUTOMATIC INDEXING MODULE TYPE: Z-1015

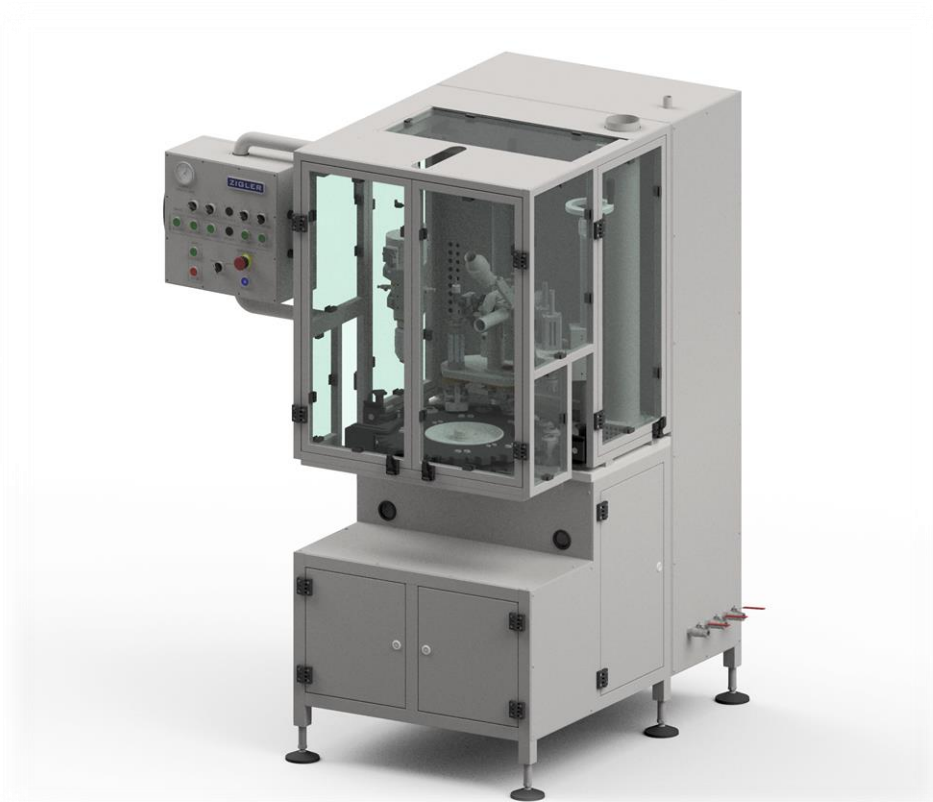

Filling and Closing Automatic Indexing Module Z-1015 is part of automatic aerosol production line and is intended for the completion of the following production phases:

- Filling aerosol cans with liquid product - performed using 1-3 filling modules (depending on order).
- Inserting valves into aerosol cans - performed by a valve inserter with an valve presence check module.
- Crimping the inserted valves.
- Putting filled and crimped cans back on conveyor.



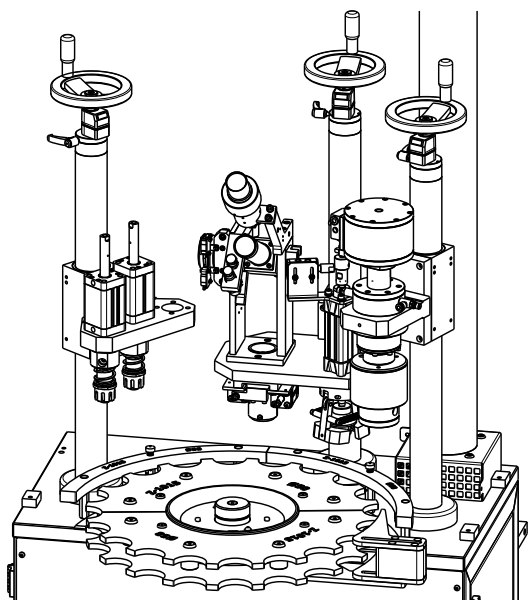

## Working parameters

Capacity: 1000 ÷ 3600 units/hour. (16 ÷ 60 units/minute)

Operation pressure: 0.6 ÷ 0.8 MPa (6÷8 bar)

## Dimensions and weight

Width: 1270 mm

Length: 1455mm

Height: 1875 mm

Weight: ~540 kg

## Power supply

Supply type: Pneumatic

Required supply pressure: 0.8 ÷ 1.0 MPa (8÷10 bar)

Compressed air quality: Class IV according to ISO 8573-1 standard for temp. 15 ÷ 35°C

Connection: External thread G $\frac{3}{4}$ "

## Liquid product connection

Required product pressure: 0.3 - 1 MPa (3 - 10 bar) – depending on the product density and viscosity

Connection: G $\frac{1}{2}$ " external BSP thread with 60° cone to each filling module

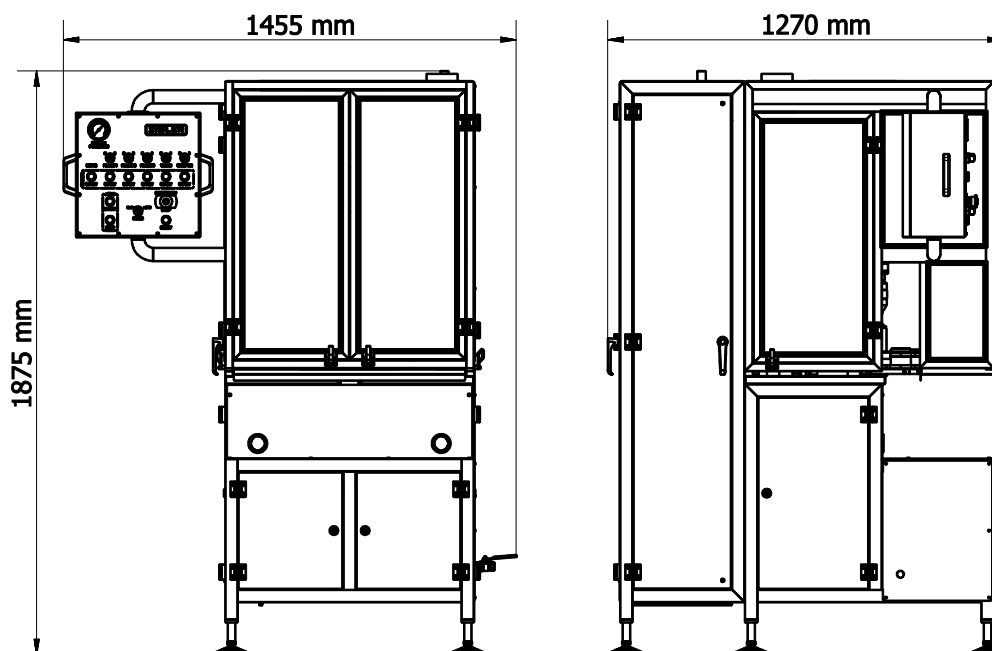

**ZIGLER POLSKA Sp. z o.o.**

ul. Braci Gutmanów 7

43-600 Jaworzno

POLAND

+48 32 616 36 70

biuro@zigler.pl

zigler@zigler.pl

www.zigler.pl

VAT UE: PL6772294223

REGON: 120491798

KRS: KRS nr 0000032816

Sąd Rejonowy Katowice-Wschód  
w Katowicach

**BANK ACC.**

**ING BANK ŚLĄSKI**

PLN 56 1050 1360 1000 0090 3033 8132

EUR 94 1050 1360 1000 0024 0995 9893

SWIFT: INGBPLPW