

FEEDING TABLE TYPE: Z-5205

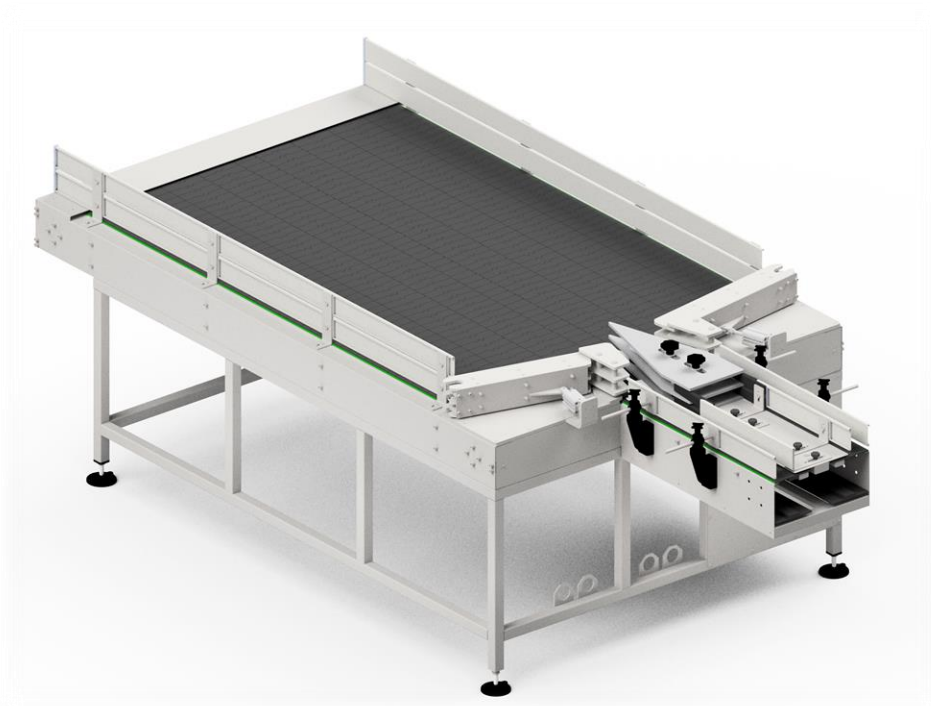

The Z-5205 type Feeding Table is an input device to the aerosol product manufacturing process line. The main task of the feeding table is to feed empty containers to the other machines on a continuous basis as required by the production line. The table is equipped with a system preventing containers from jamming in the table output segment. The table has two outfeed paths as standard and is designed to feed the containers to the process machines of the production line configured in a mirror (double) arrangement.



Dimensions and weight:

Width:	1495 mm
Length:	3200 mm
Plate surface height:	900 mm
Total height:	1090 (± 50 mm of regulation)
Feeding area capacity:	~550 pcs (ø66mm cans)
Width of feeding area:	1292 mm
Weight:	~350 kg

Drive system:

Motor power:	0.37 kW
Rotation:	1370 rpm

Supply:

Supply type:	Electric, pneumatic
Supply voltage:	3x230V AC, 50Hz
Power:	0.37 kW
Supply pressure:	8 – 10 bar (0.8 - 1.0 MPa)
Air consumption:	2.5 m ³ /h

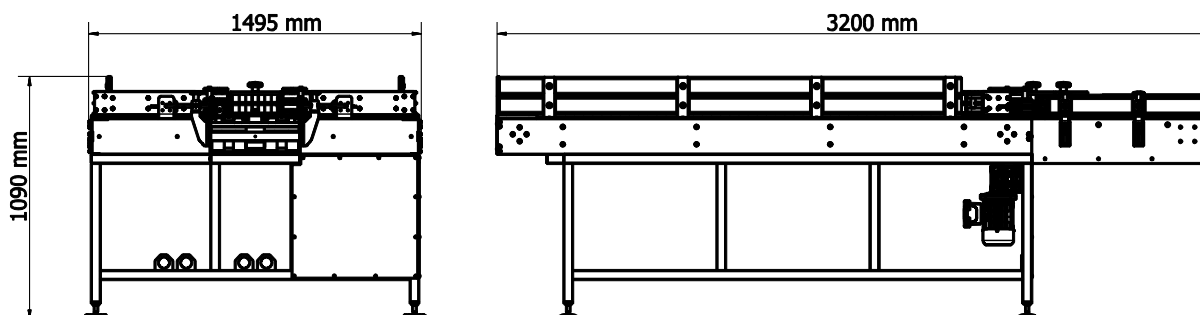

 **ZIGLER POLSKA Sp. z o.o.**

ul. Braci Gutmanów 7
43-600 Jaworzno
POLAND

 +48 32 616 36 70

 biuro@zigler.pl

zigler@zigler.pl

 www.zigler.pl

VAT UE: PL6772294223

REGON: 120491798

KRS: KRS nr 0000032816

Sąd Rejonowy Katowice-Wschód
w Katowicach

BANK ACC.

ING BANK ŚLĄSKI

PLN 56 1050 1360 1000 0090 3033 8132

EUR 94 1050 1360 1000 0024 0995 9893

SWIFT: INGBPLPW