

FEEDING TABLE TYPE: Z-5201



The Z-5201 type feeding table is an entry machine of automatic aerosol production line. The basic task of the feeding table is to provide continuous supply of empty containers in accordance to the demand of the production line. The table has been equipped with a pneumatic anti-jam rail preventing the containers from getting stuck at the output segment of the table.



Dimensions and weight:

Width:	1160 mm
Length:	2720 mm
Plate surface height:	1080 mm
Total height:	900 (\pm 50 mm of adjustment)
Feeding area capacity:	~280 pcs (\varnothing 66mm cans)
Width of feeding area:	990 mm
Weight:	~250 kg

Drive system:

Motor power:	0.37 kW
Rotation:	1370 rpm

Supply:

Supply type:	Electric, pneumatic
Supply voltage:	3x230V AC, 50Hz
Power:	0.37 kW
Supply pressure:	8 – 10 bar (0.8 - 1.0 MPa)
Air consumption:	2.5 m ³ /h

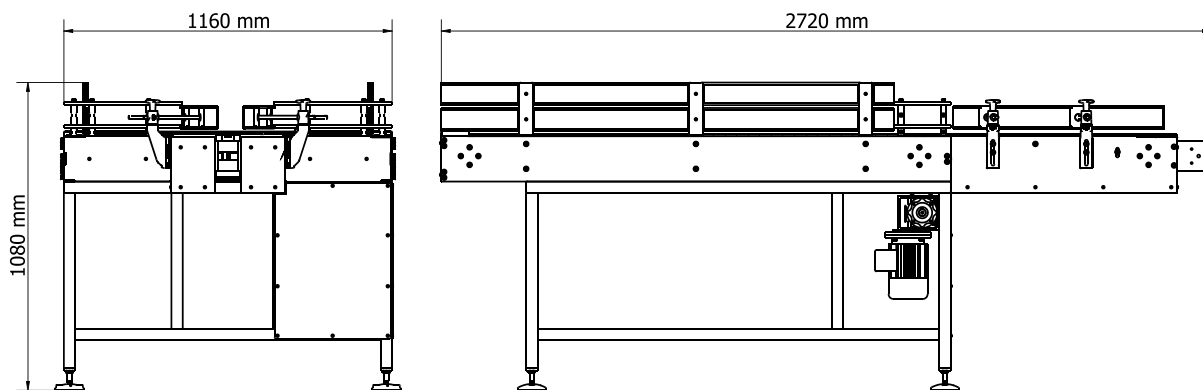

ZIGLER POLSKA Sp. z o.o.

ul. Braci Gutmanów 7
43-600 Jaworzno
POLAND

+48 32 616 36 70

biuro@zigler.pl

zigler@zigler.pl

www.zigler.pl

VAT UE: PL6772294223

REGON: 120491798

KRS: KRS nr 0000032816

Sąd Rejonowy Katowice-Wschód
w Katowicach

BANK ACC.

ING BANK ŚLĄSKI

PLN 56 1050 1360 1000 0090 3033 8132

EUR 94 1050 1360 1000 0024 0995 9893

SWIFT: INGBPLPW