

FEEDING TABLE TYPE Z-5200

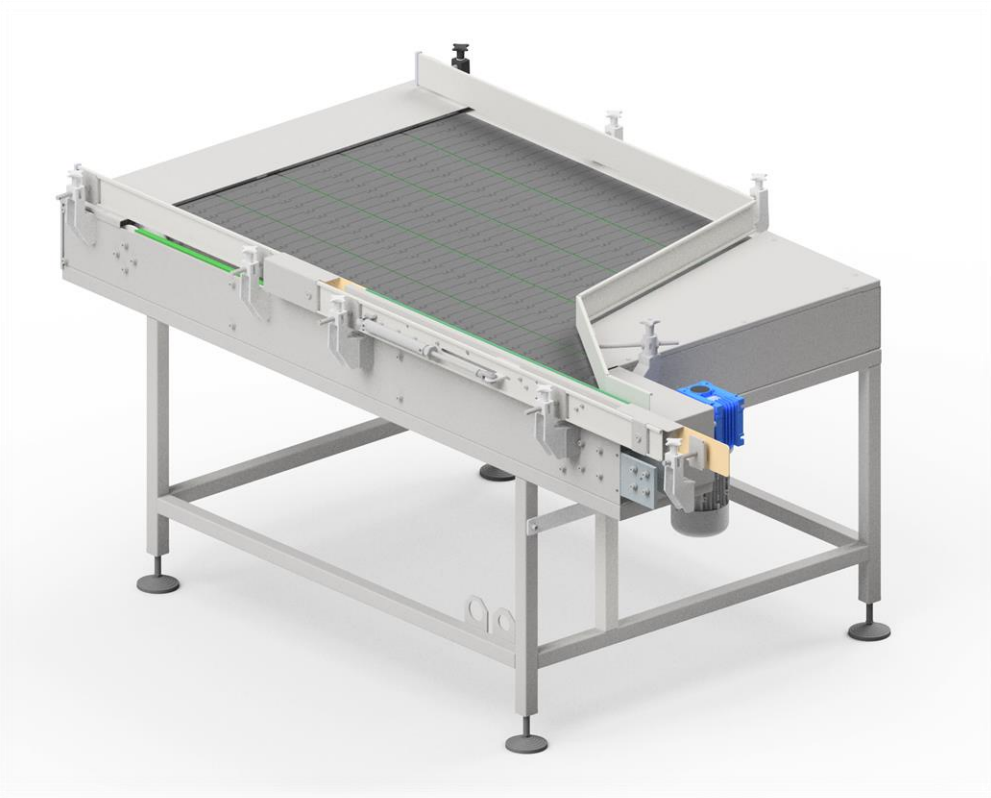

The Z-5200 type feeding table is an entry machine of automatic aerosol production line. The basic task of the feeding table is to provide continuous supply of empty containers in accordance to the demand of the production line. The table has been equipped with anti-jam rail preventing the containers from getting stuck at the narrowed output segment of the table.

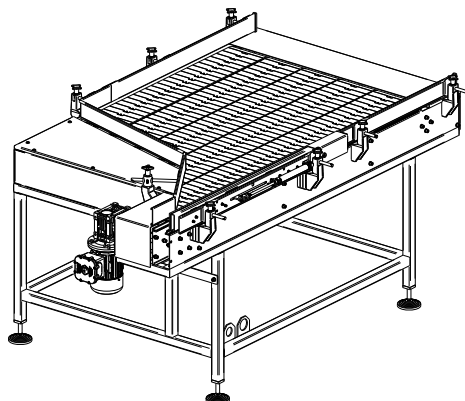



Dimensions and weight:

Width:	1350 mm
Length:	2015 mm
Plate surface height:	900 mm
Total height:	1000 (± 50 mm of adjustment)
Feeding area capacity (for ø66mm cans):	~260 pcs
Width of feeding area:	1035 mm
Weight:	~225 kg

Drive system:

Motor power:	0.37 kW
Rotation:	1370 rpm

Supply:

Supply type:	Electric, pneumatic
Supply voltage:	3x230V AC, 50Hz
Power:	0.37 kW
Supply pressure:	8 – 10 bar (0.8 - 1.0 MPa)
Air consumption:	2.5 m ³ /h

