

FEEDING TABLE TYPE: Z-5215

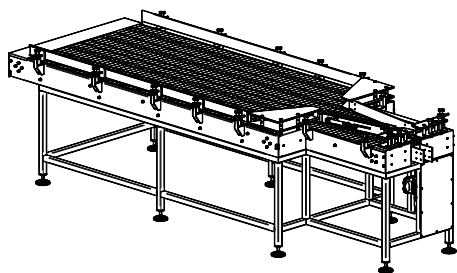

Feeding table Z-5215 is an input machine of the production line for the aerosol products manufacture. Basic function of the feeding table is to continuously supply empty cans as required by the production line. The table has been equipped with anti-jam rail preventing the containers from getting stuck at the narrowed output segment of the table.





Dimensions and weight:

Width:	1365 mm
Length:	3620 mm
Plate surface height:	900 (± 50 mm of adjustment)
Total height:	1035 mm
Feeding area capacity	~600 pcs
(for ø66mm cans):	
Width of feeding area:	1090 mm
Weight:	~400 kg

Drive system:

Motor power:	0,37 kW
Rotation:	1370 rpm

Supply:

Supply type:	Electric, pneumatic
Supply voltage:	3x230V AC, 50Hz
Power:	0,37 kW
Supply pressure:	8 – 10 bar (0.8 – 1.0 MPa)
Air consumption:	2.5 m ³ /h

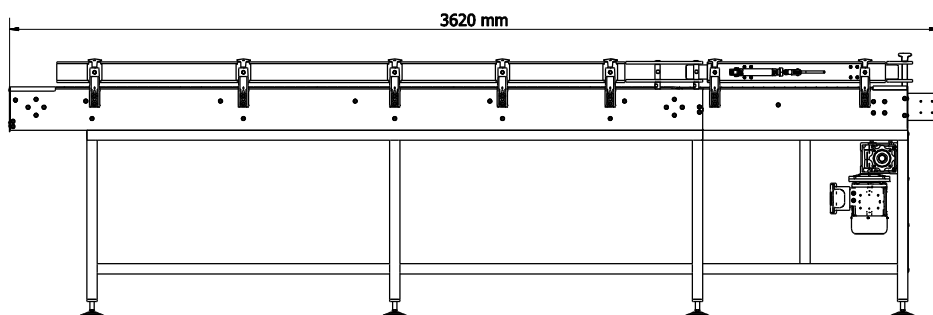
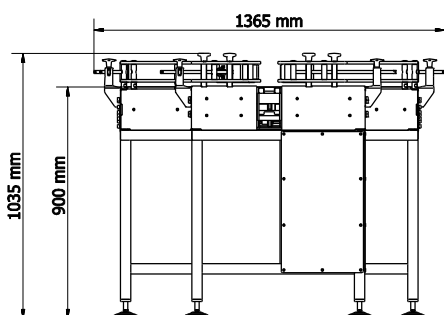

ZIGLER POLSKA Sp. z o.o.

ul. Braci Gutmanów 7
43-600 Jaworzno
POLAND

+48 32 616 36 70

biuro@zigler.pl

zigler@zigler.pl

www.zigler.pl

VAT UE: PL6772294223

REGON: 120491798

KRS: KRS nr 0000032816

Sąd Rejonowy Katowice-Wschód
w Katowicach

BANK ACC.

ING BANK ŚLĄSKI

PLN 56 1050 1360 1000 0090 3033 8132

EUR 94 1050 1360 1000 0024 0995 9893

SWIFT: INGBPLPW