

## CONVEYOR TYPE: Z-5400

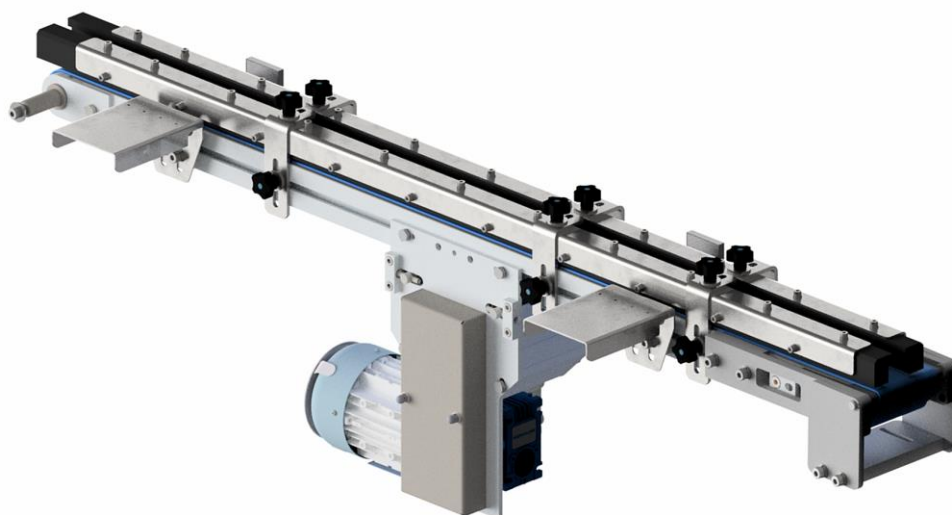

Main purpose of Conveyor Z-5400 is to transport small size elements like sprayheads, caps, screw caps, adapters etc. between the sorter and inserting/placing machine.

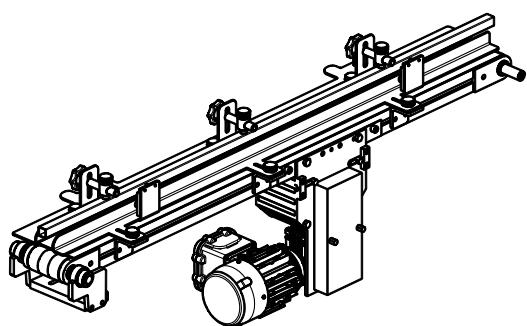

### Dimensions and weight:

Width: Total width ~275 mm;  
Belt width ~90 mm  
Length: Depending on order  
Weight: Depending on length  
(up to 40 kg)

### Supply:

Supply type: Electric  
Supply parameters: 3x400V, 50Hz  
Power: 0.09 kW

