

COLLECTING TABLE TYPE: Z-5102

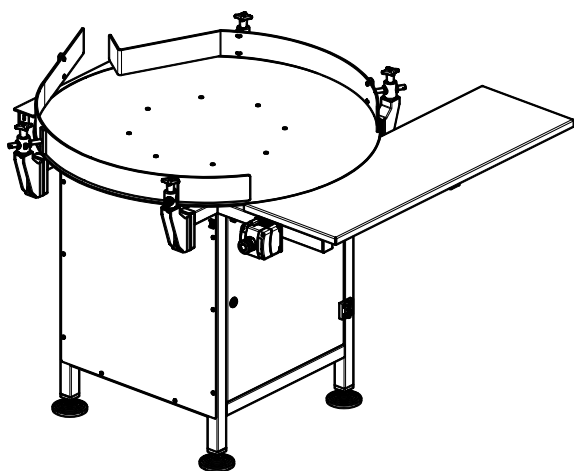

The Z-5102 Collecting Table is usually the last machine of the aerosol production lineup and is intended for receiving, bundling and packing finished products. It is equipped with a rotating worktop that allows the finished products to move towards the axis of the table, and an auxiliary table that allows for convenient placement of collective packages in order to fill them with manufactured articles.





Dimensions and weight:

Width: 1280 mm
Length: 1355 mm
Height: 980± 50 mm
Weight: ~145 kg (with drive)

Drive system:

Motor power: 0.37 kW
Rotation: 1370 rpm
Reducer ratio: i=80

Supply:

Supply type: Electric
Supply voltage: 3x230V AC, 50Hz
Power: 0.37 kW

