

CAP SORTER WITH ELEVATOR TYPE: Z-6201



Caps Sorter with elevator Z-6201 is a machine for automatic feeding properly oriented aerosol caps to caps conveyor and further to the Caps Inserter Z-1102 unit. Device is equipped with a large feeding hopper, an elevator transporting caps from feeding hopper to sorting hopper and sorter, whose task is cap reorientation. Automatic operation is controlled by a sorting hopper fill level sensor. The device is powered and controlled electrically. With removable sorting discs and guiding rails it is possible to work with different diameters of aerosol caps.



ZIGLER

AEROSOL & FILLING TECHNOLOGY

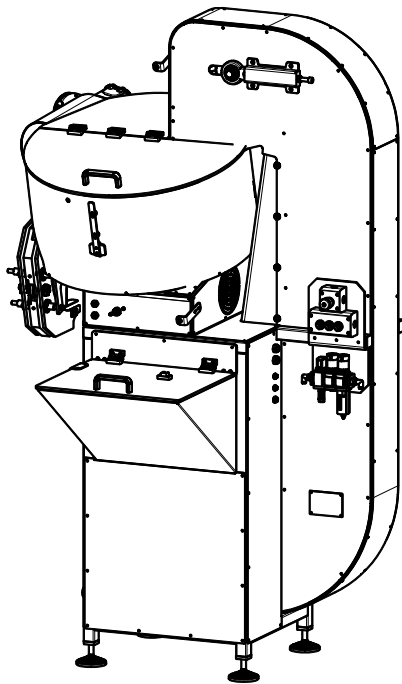

Dimensions and weight:

Width: 1355 mm
Length: 1330 mm
Height: 2180 mm
Weight: ~300 kg

Supply:

Supply type: Electric and pneumatic
Supply voltage: 3x230V 50Hz, 3x400V 50Hz
Power: 0,46 kW + 0,37 kW
Supply pressure: 8 - 10 bar
Air consumption: 3m³/h

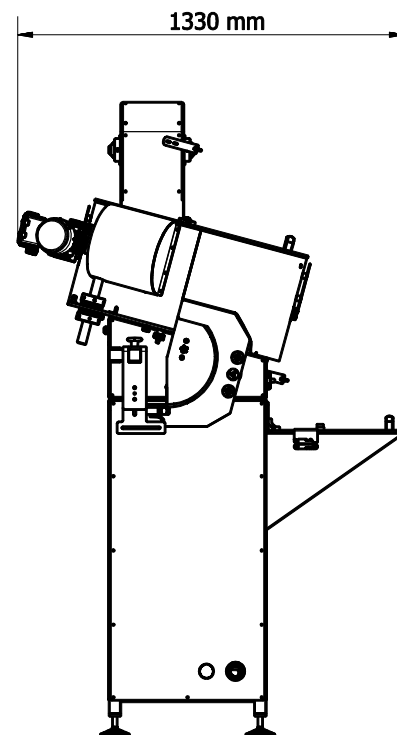
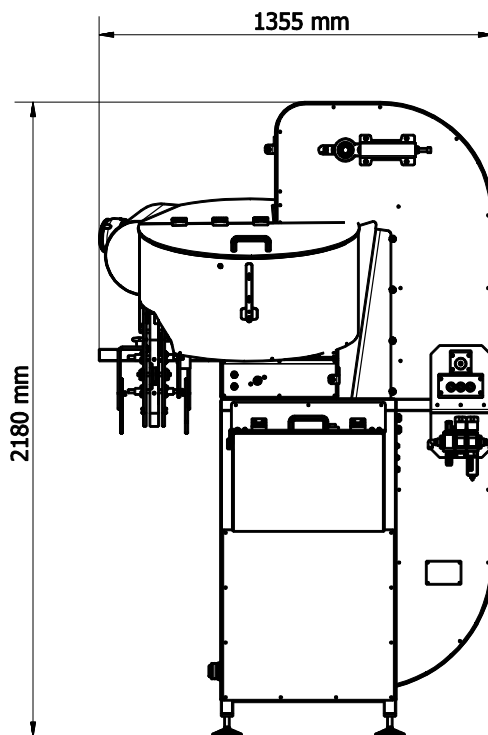

ZIGLER POLSKA Sp. z o.o.
ul. Braci Gutmanów 7
43-600 Jaworzno
POLAND
+48 32 616 36 70

biuro@zigler.pl
zigler@zigler.pl
www.zigler.pl

VAT UE: PL6772294223
REGON: 120491798
KRS: KRS nr 0000032816
Sąd Rejonowy Katowice-Wschód
w Katowicach

BANK ACC.
ING BANK ŚLĄSKI
PLN 56 1050 1360 1000 0090 3033 8132
EUR 94 1050 1360 1000 0024 0995 9893
SWIFT: INGBPLPW