

AEROSOL TEST BATH TYPE: Z-7505



Aerosol Test Bath is intended to be used for improvement of aerosol products quality and safety rules of its usage by helping to identify a leaking aerosol cans in course of production cycle. According to accepted standards, testing proceeds by bathing filled and closed aerosol containers in water at 55⁰C for about 3 minutes. Containers are being transported through a tank filled with hot water by means of driving wheel and a chain with clips for holding the attached containers. Speed of attaching/detaching is smoothly regulated and allows to adapt Test Bath to the capacity of entire line. Total capacity (assuming that bath will last 3 min) comes to about 60 containers per minute. Test Bath has been also equipped with pneumatic drying system for containers.



ZIGLER

AEROSOL & FILLING TECHNOLOGY

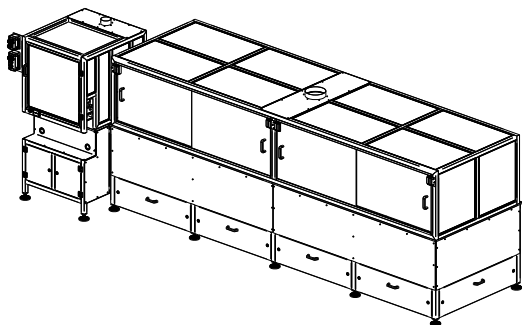

Working parameters:

Production capacity:	60 pcs./min.
Containers diameter:	ø35 – ø65 mm (depending on installed grippers)
Containers height:	80 – 320 mm
Valves type handled:	Standard aerosol 1" valve
Duration of test bath:	180 sec.
Water temperature:	55°C
Leakage detection (optional – depending on order):	Infrared or catalytic gas detectors

Overall dimensions and weight:

Width:	1737 mm
Length:	5131 mm
Height:	1750 mm
Weight:	~1500 kg

Power supply:

Type of power supply:	Electrical and pneumatic
Electrical supply:	3x400 VAC 50 Hz; 3.55 kW
External control:	24V DC
Air supply pressure:	8 – 10 bar (0.8 – 1.0 MPa)
Air consumption:	70 m ³ /h

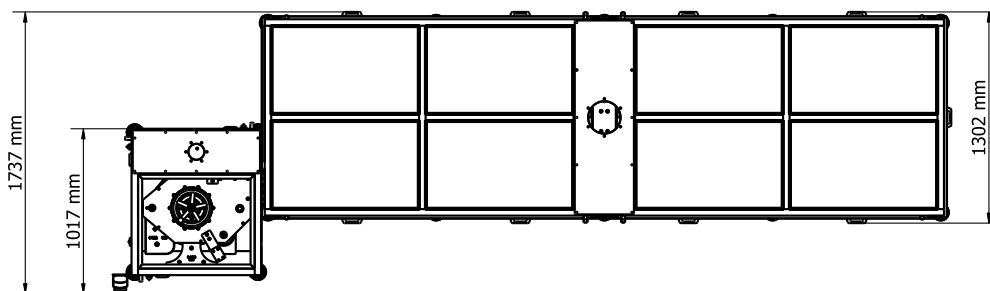
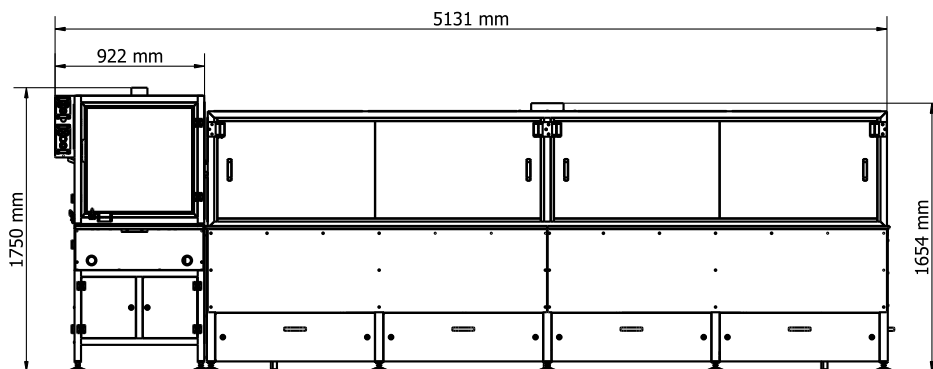

 **ZIGLER POLSKA Sp. z o.o.**

ul. Braci Gutmanów 7
43-600 Jaworzno
POLAND

 +48 32 616 36 70

 biuro@zigler.pl

zigler@zigler.pl

 www.zigler.pl

VAT UE: PL6772294223

REGON: 120491798

KRS: KRS nr 0000032816

Sąd Rejonowy Katowice-Wschód
w Katowicach

BANK ACC.

ING BANK ŚLĄSKI

PLN 56 1050 1360 1000 0090 3033 8132

EUR 94 1050 1360 1000 0024 0995 9893

SWIFT: INGBPLPW



 **ZIGLER POLSKA Sp. z o.o.**
ul. Braci Gutmanów 7
43-600 Jaworzno
POLAND
 +48 32 616 36 70

 biuro@zigler.pl
zigler@zigler.pl
 www.zigler.pl

VAT UE: PL6772294223
REGON: 120491798
KRS: KRS nr 0000032816
Sąd Rejonowy Katowice-Wschód
w Katowicach

BANK ACC.
ING BANK ŚLĄSKI
PLN 56 1050 1360 1000 0090 3033 8132
EUR 94 1050 1360 1000 0024 0995 9893
SWIFT: INGBPLPW